

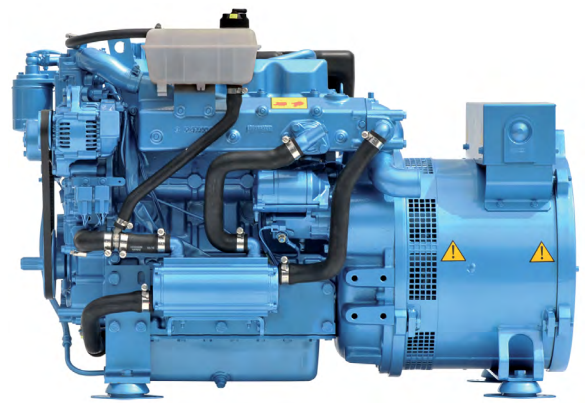

Generator set Nanni QMS16M

16.2 kW max at 1500 rpm



Engine base

- 4 strokes Diesel engine tested in all marine or industrial applications throughout the world.
- Engine block in cast iron type tunnel and timing gear.

Injection and combustion system

- The Super Glow System comes as standard equipment to start the engine in cold temperatures.
- The E-TVCS injection system produces an ideal air/fuel mixture by creating three vortices in the combustion chamber. The combustion efficiency is improved, resulting in low fuel consumption.

Cooling system

- Cooling is ensured by heat exchange between coolant and seawater in a heat exchanger, or via a Keel Cooling system.
- Seawater pump with rubber impeller.

Generator

- Delivering a continuous power of 13.9 kW and able to provide up to 16.2 kW.
- IP21 protection (additional level available on demand).

Engine main features

- Kubota base Diesel engine
- 4 cylinders in line
- Closed cooling with heat exchanger
- Engine block in cast iron

Generator main features

- Class H insulation
- 50 Hz
- Voltage accuracy of $\pm 1.5\%$
- Radio interference suppression
- Electronic regulator

Generator set ratings

Voltage (V)	Frequency (Hz)	Amperes (A)		Power * (kW)	
		max	cont.	max	cont.
230	50	70.4	60.4	16.2	13.9

Single-phased output with power factor $\cos \phi = 1$
*Continuous (COP) and max (PRP) power rating according to ISO 8528-1

Weight and dimensions

	Without sound shield	With sound shield
Dry weight (kg)	328	378
Length (mm)	1014	1130
Width (mm)	548	600
Height (mm)	691	700

Standard equipment

- Extension delivered by meter
- Closed cooling with heat exchanger
- Wet exhaust
- 12V Single-pole electrical system
- Safety shutdowns on low oil pressure and high coolant temperature
- Eco GE panel
- Rubber mounts
- Oil drain pump mounted on the engine

Optional equipment

- Seawater hoses
- Seawater filter
- Siphon breaker
- Fuel feed system piping
- Exhaust system
- Fuel prefilter
- Keel Cooling
- Vertical dry exhaust
- 12V Double-pole electrical system
- Luxe GE panel (instead of Eco GE panel)
- Additional electric fuel feed pump

Generator set QMS16M

Engine specifications

Engine base	Kubota
Cycle	4 strokes Diesel
Number of cylinders	4 in line
Displacement (cm ³)	2197
Bore and stroke (mm)	87 x 92,4
Combustion system	Indirect (E-TVCS)
Rated rpm	1500
Intake	Natural

Fuel system

Fuel injection pressure (bar)	140
Fuel injection pump	In line, Type Bosch MD mini
Fuel feed pump	Mechanical
Governor type	All speed mechanical

Cooling system

Seawater pump	Neoprene rotor
Coolant pump type	Coaxial alternator driven
Coolant capacity (l)	7.5
Exhaust manifold	Fresh water cooled
Exhaust elbow.	Water injected
Max allowable back pressure (bar)	0.127
Max exhaust gas temperature (°C)	550

Lubrication system

Oil pan capacity (l)	7.5
Oil type	API-CF mini 15W40
Oil filter	Full flow type filter
Lubrication system	Forced by trochoid pump

Engine Electrical System

Engine alternator (V-A)	12 - 40
Battery recommended (Ah)	120
Starter motor (V-kW)	12 - 1.4

Fuel consumption

Fuel consumption at full load (l/h)	4.8
-------------------------------------	-----

Air requirements

Combustion air at 25°C (m ³ /h)	90
Flow for the evacuation of radiant heat (m ³ /h)	430

Installation data

Exhaust connexion (mm)	50
Fuel connexion (mm)	8
Fuel pump - Max suction height (m)	0.5 (Standard pump) 1.8 (with add. electrical pump)
Sea Water pump connexion (mm)	32
Engine Operating Angle	15° continuous (30° maxi)

Nanni Industries S.A.S. France

11,Avenue Mariotte-Zone Industrielle

33260 La Teste France

Tel : + 33 (0)5 56 22 30 60

Fax : +33 (0)5 56 22 30 79

www.nannidiesel.com

Certified



Instrument panel

Eco GE

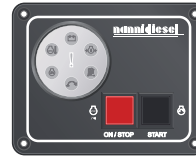

Luxe GE



- Start and stop buttons
- Low oil pressure warning light
- Coolant temperature warning light
- Preheat warning light
- Battery charge warning light
- Oil pressure indicator *
- Coolant temperature indicator *

*Only on Luxe GE panel

Main components

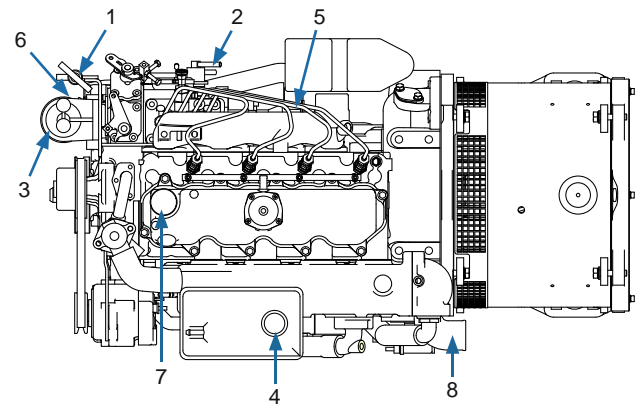

- | | |
|-------------------|--------------------|
| 1. Oil drain pump | 5. Seawater pump |
| 2. Fuel feed pump | 6. Oil filter |
| 3. Fuel filter | 7. Oil filler port |
| 4. Expansion tank | 8. Exhaust elbow. |

Your dealer

