

N9.380 CR2

Specifications

Power at crankshaft	280 kW [381 hp]
Displacement	9 l [549 in ³]
Configuration	6 cylinders in line
Operation type	4 stroke Diesel
Bore & Stroke	118.4 x 136 mm [4.66 x 5.35 in]
Compression ratio	16,3:1
Rated speed	2200 rpm
Idling speed	650 rpm
Peak torque	1572.8 Nm
Peak torque speed	1700 rpm
Dry weight	948 kg [2089 lbs]

Engine base	John Deere
Fuel system	Direct injection High pressure Common Rail Electronically controlled
Air intake	Turbocharged Air-to-seawater aftercooler
Cooling	Closed cooling with heat exchanger
Max mounting angle	0° Front up 12° Front down
Alternator	24 Volt 100 Amp
Rating	M2
Emission compliance	IMO Annex VI compliant EPA marine Tier 3 NRMM 97/68/EC

N9.380 CR2

280 kW [381 hp] at 2200 rpm

TECHNICAL DESCRIPTION

Engine block

- Replaceable wet-type cylinder liners
- 4 valves per cylinder
- Watercooled exhaust manifold

Fuel system

- Primary & secondary fuel filter
- Common Rail fuel injection system

Lubrication system

- Replaceable full-flow oil filter
- Oil dipstick
- Oil cooler

Cooling system

- Closed cooling with heat exchanger
- Gear driven self-priming raw water pump
- Coolant circulating pump
- Water cooled exhaust elbow

Electrical system & Instrumentation

- 24V 100A alternator
- 24 Volt starter motor
- Complete instrumentation including key switch and alarms
- Extension cable harness with plug-in connection

Air intake

- Water cooled turbocharger
- Air-to-seawater aftercooler

Other features

- Flywheel SAE 2
- Damper pulley
- Flexible engine mounting

Optional equipment & accessories

- Keel cooling adaptation
- Dry exhaust elbow
- Complete marine propulsion systems
- Marine transmission adaptation kits
- Throttle and shift controls
- Additional instrumentation, Flying bridge extension harness
- Rigid engine mounting
- Power take off
- Type approval

RATING

- Up to 5000 annual operating hours
- Load factor up to 65%
- Full power for no more than 16 hours out of each 24 hours of operation. The remaining operation time must be at or below cruising speed

TRANSMISSIONS

Contact your local dealer for more details and availability for transmission model and type.

PERFORMANCE CURVES

Power at crankshaft

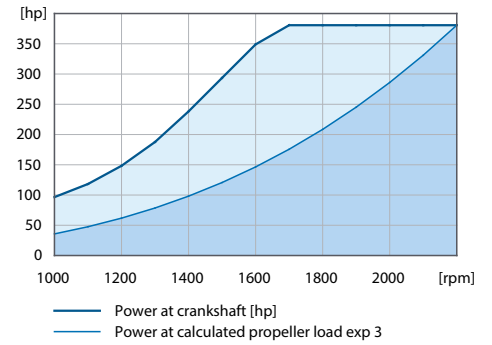

Torque at crankshaft

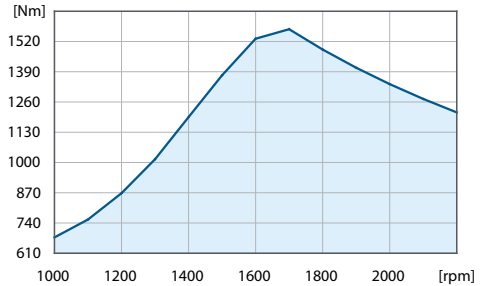

Fuel consumption

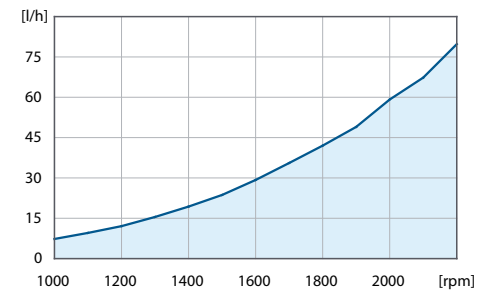

DIMENSIONS BOBTAIL

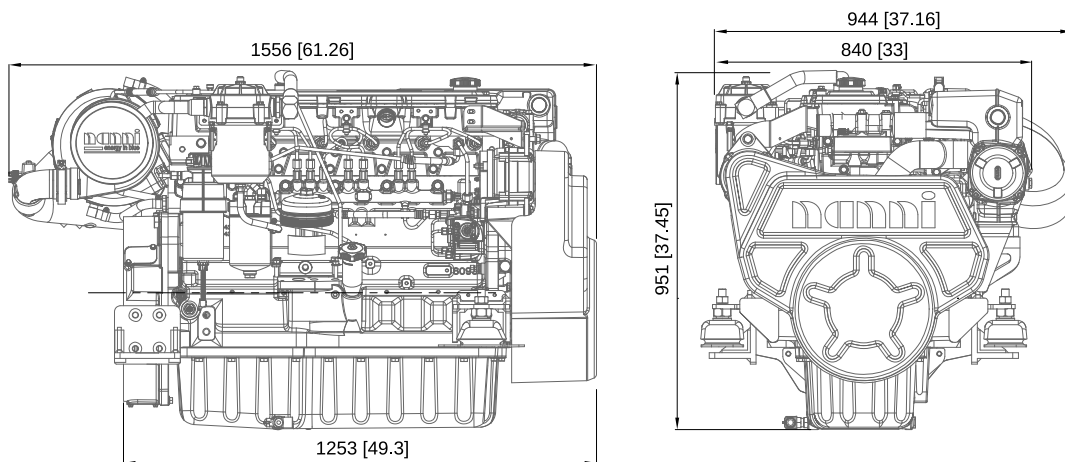

Nanni Industries S.A.S. France
11, Avenue Mariotte - Zone Industrielle
33260 La Teste - France
Tel: +33 (0)5 56 22 30 60
Fax: +33 (0)5 56 22 30 79

Nanni Trading S.R.L.
Via Degli Olmetti, 5/B
00060 Formello (RM) - Italia
Tel: +39 06 30 88 42 51/52/53
Fax: +39 06 30 88 42 54

Technical data according to ISO 8665. Specifications are subject to change without notice. Images and illustrations may show non standard equipments. All combination of equipment & accessory are not available.

20151118-A ENG